

Remote Input Command

General

When designing an emergency egress lighting system, the objective must be to provide as much life safety protection as possible. The ability to monitor utility

power alone is not sufficient. If downstream breakers trip or if there is insufficient voltage to the lighting panels, you may be "left in the dark". The ability to simultaneously

monitor multiple emergency locations is critical. Ideally this will not increase NFPA compliance expense.

The eLITE & UltraLITE

The eLITE and UltraLITE systems will accept a Remote Input Command On signal. This feature allows the monitoring of multiple locations and events. The Remote Input Command On feature requires a normally closed contact provided by

the customer. If an unacceptable condition exists at one or more of the locations being monitored, the resulting open contact energizes the normally off bus, illuminating normally off emergency lights. Once conditions return to normal,

the normally off bus is de-energized and the emergency lights return to their normally off state. Remote Input Command On may be activated via a signal from any architect / engineer dedicated monitoring point.

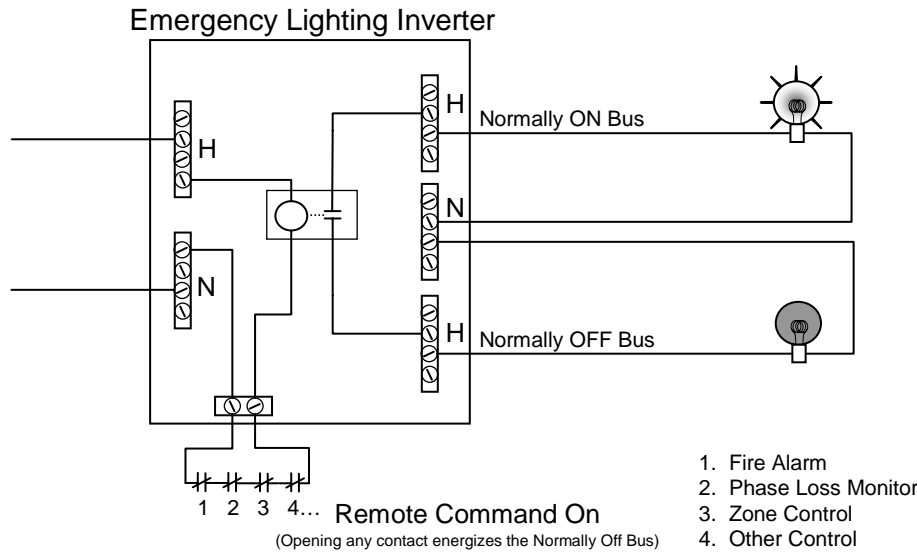

Summary

The eLITE and UltraLITE can be used to improve an emergency egress lighting system. By utilizing the Remote Input Command On feature, not only is utility

failure monitored, but downstream electrical issues are also monitored and acted upon. Fire alarm panels can be monitored as well. Occupant safety is

increased significantly when the Remote Input Command feature is specified. NFPA compliance expense is also minimized.