

# Local Control Override with Zone Saver

## General

The ability to manually control emergency egress lighting can provide significant energy savings while still assuring occupant safety. In the event of a

power failure, it is necessary to bypass a control device (wall switch, dimmer, occupancy sensor, photocell, energy management, etc.) to insure

that full illumination of the lighting fixtures is achieved during the emergency condition, thus providing safe egress.

## Zone Saver & Local Control Override

Zone Saver, used with a Controlled Power Company lighting inverter, overrides local control devices and insures full illumination to emergency lighting during a power outage. The Zone Saver allows independent control (via wall switch, dimmer, occupancy sensor, photocell, energy management, etc.) of lighting fixtures during normal power conditions. However in the event of a power failure, ZoneSaver will automatically override the control of selected fixtures and insure their full illumination for safe egress.

ZoneSaver is capable of supplying two separate single pole, 20 amp circuits at 120VAC or 277VAC, or one 2 pole, 20 amp circuit at 208VAC or 240VAC. Depending on the size of the lighting inverter, multiple Zone Savers can be used for larger applications involving many lighting control devices. When Zone Saver is used as a local control override, Control Modules #1 & #2 either allow local control of both circuits (selected fixtures) when utility power is present or bypass that control when utility power is

lost. The Zone Saver has color lamps which indicate device status. When utility voltage is available at the sensing circuit input, the "green" utility light is illuminated indicating a normal condition. Local control is allowed. When utility power is lost, a red emergency light is illuminated, the control device is bypassed and full nominal voltage is diverted to the selected emergency fixtures, providing full illumination. A Test Switch is provided to manually test the emergency circuits per NFPA 101.

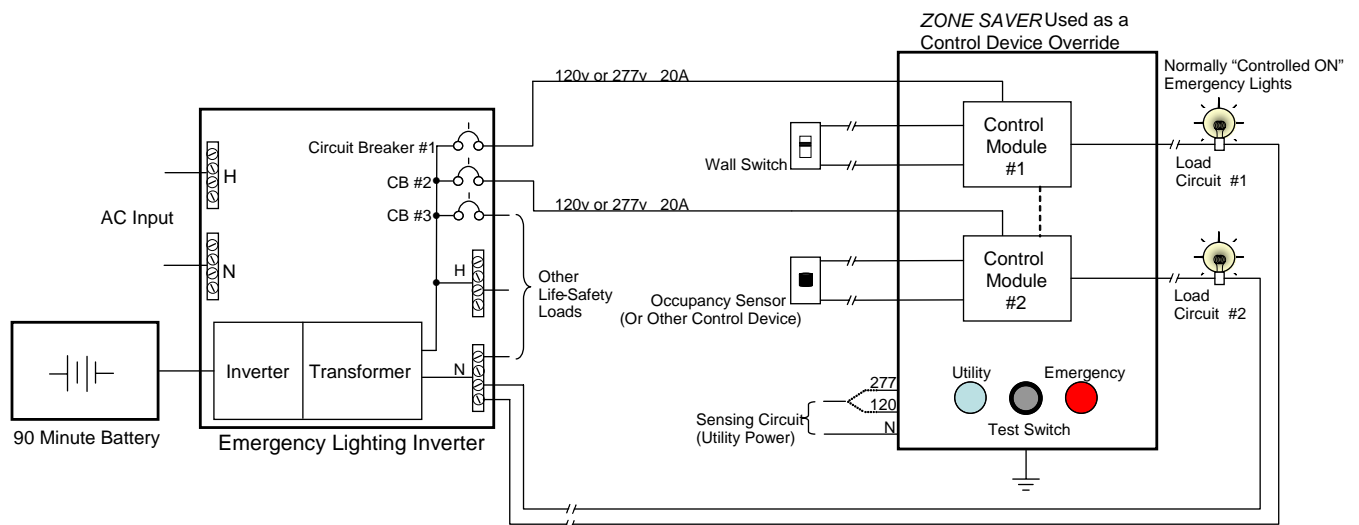

## Housing

The Zone Saver is provided in an enclosure constructed of a 3-gang masonry box fabricated from 16 gauge

galvanized steel. It has an acid resistant, off-white powder coat finish, a faceplate made of 18 gauge

galvanized steel and pre-wired, color coded leads routed through the attached 6' flexible conduit.

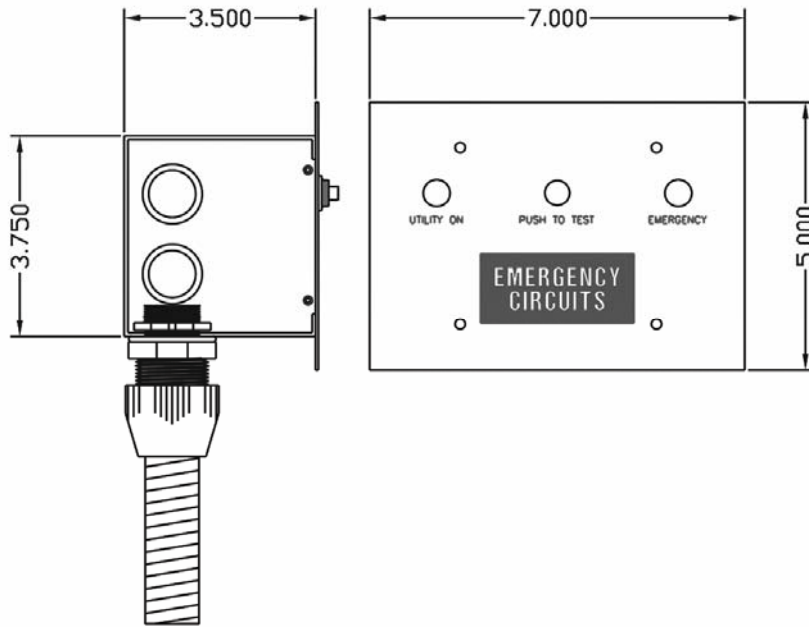

## Summary

The purpose of a local control override device is to bypass a control device such as a wall switch, dimmer, occupancy sensor, photocell, energy management system etc. so that the lighting fixtures illuminate fully during an emergency condition

insuring safe egress. Zone Saver, when used with a Controlled Power Lighting Inverter, provides two separate single pole, 20 amp circuits at 120VAC or 277VAC, or one 2 pole, 20 amp circuit at 208VAC or 240VAC which can be bypassed. Depending on the

size of the lighting inverter, multiple Zone Savers can be used for larger applications involving many lighting control devices. A test switch is also provided to manually test the emergency circuits per NFPA 101.